



**INNOVATION
IN PRESERVATION**

ON-DEMAND COMBINATION MACHINE



CRACK SEAL



MASTIC PATCH

TWO UNIQUE NEEDS, ONE GREAT MACHINE

- Minimum impact to traffic
- Easy operation
- All-Day production



CRACK SEALING

At the core of the C1 is MAGMA M Series cracksealer. Using the standard 150 gallon tank size operators will continue to operate with the fastest melting and safest operating cracksealer in its class.

Standard Features:

- Lowest load height and largest loading door in class
- Stress free boom with center pivot
- Weather proof simple seal controller
- Performance sealant tank design
- Standard heated wand or optional aluminum wand



Standard Wand



Electric Heated Wand Option

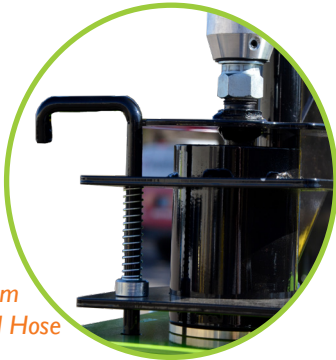

Stress-free Boom
Rotates Around Hose



Performance Tank Design



Simple Seal Controller



MASTIC PATCHING

On-Demand production of the highest quality patching material. The CI uses an innovative patent pending design to provide contractors and government agencies the flexibility to perform both function with minimal impact to traffic flow.

Standard Features:

- Up to 24,000 lbs. of patching material per 8-hour shift.
- Side discharge chute for ease of center line repairs
- Pivoting and heated trough for ease of placement
- Use locally sourced aggregate in patent pending mixing system
- Onboard tool heater with standard box screed and iron



Side Discharge



Standard Applicator Box



Lowest Load Height Largest Door



Aggregate Feeding System

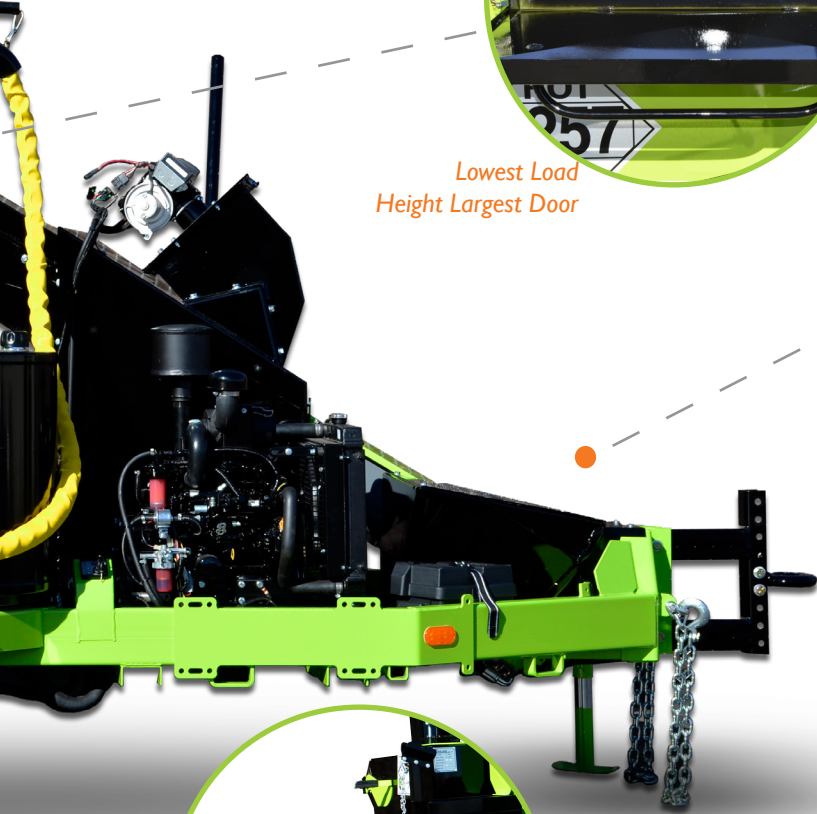

Standard Heated Off-Set Material Chute

RETURN ON INVESTMENTS

On-Demand Mastic



Heat Up



Mastic Production

24,000 lb/8 shift

Factory Packaged Mastic



Heat Up



Mastic Production

Heat Up

Mastic Production



Heat Up

Mastic Production

Heat Up

~10,000 lb/8 shift per unit

SPECIFICATIONS

Material Capacity	150 gallons (568 liters)
Engine	19 hp
Heating Method	Diesel
Material Heating Rating	250,000 BTUs
Agrigate Heating Rating	250,000 BTUs
Material Pump	20 gpm
GVWR	7733 lbs
GAWR	7000 lbs
Axles/ Suspension	2 torsion
Brake Type	Electric
Material Loading Height	50 in
Rock Loading Height	32 in
Loading Doors	Single Curbside
Fuel Capacity	33 gallons (125 liters)
Hydraulic Capacity	33 gallons (125 liters)
Heat Transfer Oil	22 gallons (83 liters)
Dimensions	184"L x 80"W x 95"H
Shipping Weight	6500 lbs

OTHER PRODUCTS



K-Series Emulsion Applicator



M-Series Crack Sealers



P-5 Dura Patcher

Due to continuous improvement, specifications are subject to change without notice.

Distributed By:



CIMLINE PAVEMENT
MAINTENANCE GROUP

HINES
CORPORATION

cimlinepmg.com 800-328-3874